

## Join Us on the Air!



- Sunday 14.263 mHz at 2000Z
- Tuesday 3805 kHz at 8pm CST
- Thursday 3805 kHz at 8pm CST
- Friday (West Coast) 3895 kHz at 10pm CST
- Sunday 10m AM 29.050 mHz at Noon CST
- 1<sup>st</sup> Wednesday AM 3880 kHz at 8pm CST

Sunday for Technical, Buy, Sell & Swap  
Tues., Thurs., Fri., & Sunday for Ragchew

## Inside This Issue

20V on 75 M AM—III	1
From the Editors' Desk	2
CCA Cruise Reminder	3
Service Line - Fix it Part 2	5
Feature Shack	13
Did You Know ?	13
2009 Dayton Report	14
From the President	16

Visit the CCA Website

@

[www.collinsradio.org](http://www.collinsradio.org)

See our new features.

You can also renew your membership on line via the website and new PayPal link.

## In the News

- Dayton Success
- CCA Board Update
- Bud, K7RMT, to turn 90—Party

## “I AM Here” or Getting Your Collins Broadcast Transmitter on the Air - Third Installment

by Bill Carns, N7OTQ/K0CXX

### Those Extra Touches

As I write this, I am putting the finishing touches on the installation of both the 20V-2 and the 20V-3 in the AM studio here at K0CXX in Wimberley. The path from Arizona where I sold my two homes in 2006 has been a long one involving moving all the equipment a number of times (since I moved into a rental while finishing the search for my new home) and the building my new shack-shop at the new location and, finally, starting to install the equipment. The control circuitry discussed below was removed from the rim home and is now almost

all in place here.

Here we will briefly discuss the control elements that have been used and some outline information will be provided as a guideline for interfacing the control of the transmitters to the studio board and the push to talk and transmitter selection circuits. More detailed info is available if you would like it.

The control circuits include a push to latch and push to unlatch circuit which I find very convenient for PTT operation with a foot switch that does not need to be held down, a “sequencer control” circuit which automatically mutes and grounds the antenna for the receiver in use, switches the antenna to receive and then, finally keys the 20V that is selected so that all RF switching is done cold and there is a guard in place to assure that if the antenna is not connected to the transmitter in use, the transmitter will not even turn on. This sequence of relay keying is then reversed (a tricky circuit) assuring that the PTT release is also keyed cold.



Figure 1. Studio equipment installed, tubed and ready for control and audio cabling

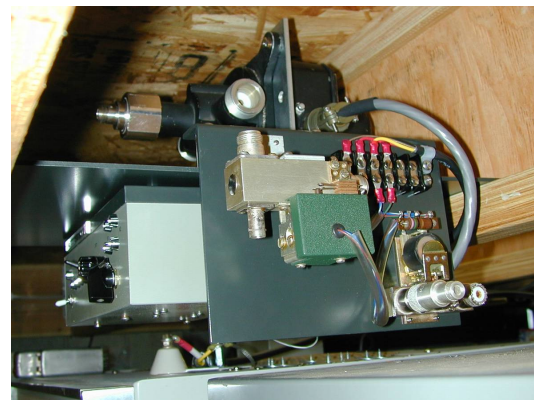

Figure 2. Sequencer and Antenna Control to be Installed above 20Vs

Also included is a picture of the 20V-3

## From the Editor's Desk

by Bill Carns, N7OTQ and Co-Editor Joe Nyberg, W1LJN

Joe writes: Attention AMers

As you are no doubt aware the 80 meter band is not always conducive to AM net operations and several recent AM nights were no exception. If you are an avid AM fan - as I am - one night a month doesn't seem to be enough to satisfy our needs - particularly if that one night is a wash-out because of band conditions. I would like to know how many members would be interested in expanding the AM night to a weekly or bi-weekly schedule. We are leaning towards bi-weekly because of net control concerns.

We are also, after a great suggestion from one of the net managers, considering having a low power segment on each of the AM night nets so that those folks running lighter power have more of a chance to get heard.

Further more, if anyone would like to try an AM net on 160 meters, let me know also.

You can contact me directly at: [w1ljn@arrl.net](mailto:w1ljn@arrl.net).

de Joe Nyberg, W1LJN  
[w1ljn@arrl.net](mailto:w1ljn@arrl.net)

Bill writes: What a quarter! After looking forward to Dayton, for a year, I pinched a nerve in my back about a month before show time and, although I was coming on the mend by mid May, there was no way for me to sit in an airline seat for the time necessary to get to Dayton - so that was that. Needless to say, I am upset that I missed it.

Dayton was a surprising success in spite of the economy being what it was (is) and the attendance at the CCA booth, the other Collins related exhibits and the CCA banquet was a resounding smash. The banquet set a all time record for attendance. I will let you read the Dayton write-up for the "rest of the story".

There have been some changes on the Collins Collectors Association Board of Directors. Due to an overload in his family life, Mac McCullough has resigned from the board. Thanks go to Mac for his service and leadership over the last several years and his participation in the elected "triad" that brought some real positive improvements to the CCA. My personal compliments to Mac, and his wife Robin, who - after a series of tragedies in their remote family, have stepped up to the bar and taken legal custody of their teenage niece. They, indeed, are to be complimented and given best wishes.

It is with GREAT pleasure that I announce to you that Bill Wheeler, the founding Father of the CCA, President Emeritus, and past board member, has agreed to again serve on the board. He has been elected to fill Mac's empty position. Welcome back Bill to the CCA board.

In addition, the board has chosen to fill the empty Vice President's slot at this time and yours truly has been elected Vice President. My focus, as always, will be on making this a quality organization that serves our

membership, makes this hobby as much fun as possible and follows a path of ethical and professional operation.

Your board has been pretty active this quarter. In summary, after orchestrating a very successful and, I might add, frugal Dayton happening (Thank you Paul), there have been several motions past by the board in the last couple of months.

First, recognizing that inflation has done its thing and costs have risen significantly since 1994, we have found it necessary to have our first dues increase since our founding in 1994. Interestingly, if our dues had just been following inflation since that time, they would now be over \$50 a year. The board has voted to set the CCA annual dues for domestic membership (U.S. and Canada) at \$32 per year if renewal is through the website and PayPal or credit card. If renewal is by snail mail, there will be an additional \$3 surcharge for handling. Foreign membership subscriptions have been set at \$40 per year regardless of renewal processing. However, we strongly encourage the use of PayPal. Dues changes are effective July 15, 2009 and will be reflected on the website. Although no one likes a dues increase, I hope that you will agree that, with the much improved *Signal* magazine, your money is being well spent. Also **PLEASE NOTE: If you do use snail mail for membership transactions, there is a new address for this in California. Do not use the Phoenix, MD address for membership.**

## Bud Whitney, K7RMT, Receives Prestigious 516F-2 Filter Choke Award at Wimberley Ham Breakfast Bud will turn 90 in October—PARTY

On the first Thursday of July, Bud Whitney, K7RMT, shared breakfast with the local hams including the local CCA gathering. During the meeting Mac McCullough presented Bud with the “516F-2 Filter Choke” award in honor of Bud’s record of overhauling over 500 516F-2s in recent years. Lord only knows how many KWM-2s he has repaired.

Bud had been presented this prestigious award at the Dayton Hamvention in absentia and did not know that he was getting it



during the breakfast. The 516F-2 Choke Award also recognizes Bud great effort in getting the 516F-2 filter chokes remanufactured at his own initial expense so that they would be available at a reasonable volume cost.

contact Bill Carns if you can make it so that we can get a pretty good estimate of who is coming.

Ya’ll Come!

## Don’t forget to sign up for the 2009 7-Day CCA Caribbean Cruise - It sails October 24th

Just a reminder that one of the big CCA events of 2009 is coming up on October 24th. There is still time to sign up via the CCA website. This will be a great experience with your fellow CCA members and promises to also be a great vacation.

There will be several operating stations on the ship including a genuine Collins station and the chance to operate from WOCXX. There is still room and time to sign up and anyone that is interested should see the CCA website for details or contact Butch Schartau who is our events manager. [k0bsbutch@gmail.com](mailto:k0bsbutch@gmail.com)





## Some Basics of Troubleshooting

- or -

### Just How Do I Fix This Danged Thing Anyway ?

#### Part 2A: The "Partially Working Set - Receivers" by Dale Svetanoff, WA9ENA



**Figure 1. Typical 75S-1 receiver set up on the test bench with test speaker and easy access turnstile.**

In Part 1 of this series, we discussed some of the basic approaches to troubleshooting and considered the case in which a given radio (or other electronic device) is "just plain dead". This time, we are going to delve deeper into the critter because when you have a set that partially works, the first thing you need to figure out is what works and what doesn't, followed by why the non-working part got that way. Again, let me remind everyone that working on tube equipment does put you in close proximity to hazardous voltages and possible high temperatures. Use both **caution** and common sense. OK, let's get started!

Observation: The author has read a lot of postings on the CCA Reflector regarding troubleshooting and repair of Collins (or other) equipment. It seems that some CCA members have well-equipped electronic work shops, but many lack all but the most rudimentary equipment (such as a DMM or VOM). It will be difficult to properly analyze some of the more challenging problems or to properly align a set that needs alignment without the correct tools. However, in an attempt to make this article more meaningful to more readers, I have included a few simplistic approaches where such methods can be used successfully and safely.

Since the main thrust of this article concerns radio sets, I'll concentrate on receivers, transmitters, and transceivers. However, many of the concepts I'll be discussing apply to related devices, such as test

## *Service Line* (Cont'd)

equipment, control consoles, and so forth. Further, since this series of articles is intended to serve as a general aid to development (or recall!) of troubleshooting skills, I want to be clear that in no way am I attempting to duplicate the radio-specific troubleshooting or alignment information found in articles dedicated to the A-Line, S-Line, or in such tools as the Hi-Res Communications videos that are dedicated to specific pieces of equipment. All of those resources, and more, are available via the CCA web site, as well as on the CCA Reflector. If you are into troubleshooting your Collins equipment, subscribe to the reflector. It contains a wealth of information.

If you have a *partially* functioning receiver, it means that the tubes ALL light up, the power supply is working, and the audio output stages and/or S-meter circuits are working. (This last point is important; if the S-meter works but you hear nothing from the speaker or headphones, you might as well get the audio stages running before you work on any other part of the set.) Try to have the manual and/or schematic of the set right with you for reference as you start work. Working “blind” can both waste time and be hazardous to you or the very set you are trying to fix. Here is a quick checklist for an initial run down on a partially functioning receiver (or receiver portion of a transceiver):

1. All tubes light up. For older sets which may have metal tubes, either feel to see if the tube is warm after a few minutes of operation (turn the power OFF - an internal short could have B+ on the metal shell) or plug the metal tubes into a tube tester. For solid state or hybrid sets (part solid state, part tubes), check to see that transistors have approximately correct operating voltages applied. Feel for any extra warm devices, as they may be shorted or overloaded. Replace any failed devices with known good ones.
2. Check for ANY sign of audio output by operating switches and controls and listening for pops or “scratchy” sounds in the speaker or head phones. For purposes of this discussion, the “audio stage” is considered to be everything between the wiper of the volume control and the loudspeaker or headphone output. (I highly recommend use of a speaker, both for convenience and safety.) Make certain that the speaker is connected and if necessary, check the continuity of the signal path from the audio output transformer (on tube sets) or the audio output driver on solid state sets. NOTE: It is usual for the headphone jack to switch off the speaker when phones are plugged into the jack. If the contacts within the jack get dirty or corroded, they may not make sufficient contact to pass audio out to the speaker. For transceivers, check the audio path for the presence of any relay switching contacts.
3. Connect an antenna and try to tune in a station, or connect an RF signal generator to the antenna terminals of the set. The “sig gen” approach is preferred because if a set is extremely “deaf”, you may not hear anything unless a really strong station can be found. A sig gen can deliver more than enough signal to confirm set operation or deficiency, yet not damage the front end of the receiver. Check this function on all bands or frequency ranges that the receiver is designed to tune.

See Figure 1 for a typical setup of a receiver and test loudspeaker on the test bench. Note the small test speaker which plugs directly into the speaker jack on the rear of the chassis. If extensive troubleshooting is expected, remove the set from the cabinet before starting work. There are some other servicing aids, test equipment, and tools that you should have either on the test bench or nearby so that you can use them as work progresses. These generally include, but are not necessarily limited to:

- Contact and control cleaners (DeoxIT™ is highly recommended for switch contacts, any good grade of spray control cleaner for pots, and denatured alcohol for cleaning grease or oil off of contacting surfaces)
- Contact burnishing tool or very fine grit emery cloth

## *Service Line* (Cont'd)

- Alignment tools that are correct for the set at hand (tools to fit trimmer caps and pots, IF (“Intermediate Frequency”) cans and pre-selector rack slugs, etc.)
- VTVM (“Vacuum Tube Voltmeter”) or DMM (“Digital Multi-Meter”) – **Caution:** If you are using a DMM, be certain that it is designed to handle voltages to at least 500 VDC if you are working on tube radios.
- Tube tester (See text for comments – yes, I know this is a contentious issue!)
- Oscilloscope or RF “Sniffer” (for confirming oscillator operation – see text and photo)
- Signal generator (preferably with selectable internal modulation and known good output level calibration)
- IF alignment generator (see text and photo) if required, along with coupling caps and connecting cable for signal injection
- Appropriate hand tools and soldering equipment as required

Referring back to the checklist, once all tubes are confirmed to be lit or all solid state devices seem to be functional, proceed to Item 2 on the checklist. An easy way to check operation of a receiver is to activate the internal crystal calibrator if the set is so equipped. For sets without a calibrator, set a sig gen to a suitable frequency within the band to which the receiver is tuned. Set its output level for about 1 millivolt (a *very* strong signal).

First, make certain that the audio stages are functioning and that you do not have bad switching connections in the audio signal path. (See discussion in Checklist item 2.) With the receiver set for either SSB or CW reception, you should get the familiar variable frequency tone as you get within a kHz or two of the calibrator’s marker signal (usually at 100 kHz marks on the dial) or the signal from the sig gen. (If your receiver is equipped only for AM reception, you will need to use a sig gen with a modulated AM signal having a constant tone, such as 1 kHz.) If you hear the calibrator or sig gen, you have a receiver that is functional, but which may need some tweaking to improve performance. If you do not hear the test signal on any band, or only on some bands, there is work to be done.

At this point, I will introduce the “Divide and Conquer” concept. You presumably know two things for certain about your radio: the power supply works and so do the audio stage and S-meter circuits. The task now at hand is to divide up the rest of the circuitry in a logical manner so as to expedite troubleshooting.

If the radio set does work on some bands, but not on others, you can skip all of the troubleshooting steps for the IF stages and filters, because they are common to all bands and are not switched. **HOWEVER:** If the radio works in some *modes, but not others*, then the problem may very well be in the IF filters. They are switched when selecting between “CW”, “LSB”, “USB”, or “AM”. So, if your set works on some bands, in all modes on those bands, proceed to looking at the RF Front End of the set. In the case of transceivers, there is considerable relay switching of circuits. Poor contact in one or more of the relays can, and will, result in erratic operation, or no operation at all. Do not forget to check continuity of signal paths through the relay contacts (with power off!) when tracing erratic operation of your KWM-1 or KWM-2.

Use of the “shotgun” approach to troubleshooting is not endorsed by this writer. (“Shotgun” means total replacement of tubes and/or other parts, such as capacitors, without first determining which ones may be defective or weak. This destroys all prior alignment and still may fail to correct the actual problem.) It is also important that you, the reader, have a basic understanding of how superhet receivers work. It is beyond the scope of this article to delve into receiver theory or design issues, except as required for specific instances as described. Know what you are doing before you dive into the set and start making adjustments without any idea of what each one should do.

## *Service Line* (Cont'd)

Case 1: The audio stages are working (you hear a slight hiss and/or hum from the speaker that varies with volume control position), but no tone when tuning for the crystal calibrator or sig gen signal. The problem could be in either the IF stages or the “front end”. Since the audio stage is working, the best course of action would be to check out the IF stages because they immediately precede the audio section. The IF stages include all circuitry after the first mixer, which typically includes:

- The first IF (one or two stages)
- A second mixer and second oscillator (not in all radios, but usual for Collins sets - the 70K-2 PTO is the second oscillator in S-Line equipment)
- The second IF (two or three stages)
- The filters used for selectivity (could be from 1 or 5, or more, IF filters), which may be mechanical, crystal, or lumped L-C components or combinations thereof
- The detector(s) used to derive the content from the received signal
- AGC circuits
- Accessory IF functions (such as Q multipliers, variable notch rejection filters, and so forth)

OK, now what? Take the IF section a small bit at a time, starting with those stages located just ahead of the detector and audio system. Remember, you are trying to do two things: 1) Determine if the IF stages are working; 2) If the IF is not working, where is the failure? At this time, you will need a sig gen that can deliver a test signal at the second IF, which is typically 455 kHz in most sets. Due to very tight selectivity of some IF filters, you may get false indications of failure unless your test signal is very close to being at 455 kHz. You can use a general purpose RF sig gen if you can set its frequency with an accuracy of 100 Hz or better (use of a frequency counter may help) or use a dedicated IF sig gen made for the purpose. Whichever instrument you use, be certain to use a safety coupling capacitor in series with the output to protect the instrument in case you tap directly onto the plate supply of an IF amplifier (with a typical value of 150 volts!). I like to use a 0.001  $\mu\text{f}$  disc ceramic for the job.

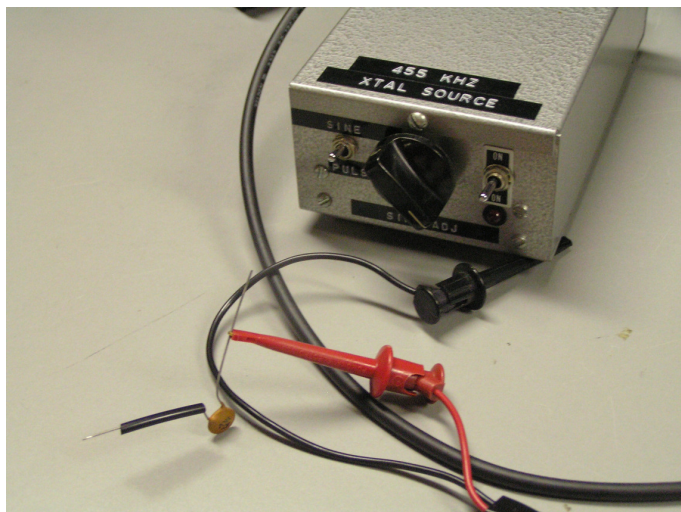

**Figure 2. Easily constructed home brew 455 kHz test oscillator and injection probe**

See Figure 2 for a 455 kHz alignment sig gen and signal cable with safety cap included. Note the black insulating sleeve over the output end of the cap. That is there to minimize accidental shorting of circuitry in the area around where the signal is being injected.

I suggest setting the output of the sig gen to about 400 to 500 microvolts. Inject this signal AFTER the IF filters. (Note: In the 75S-1 receivers, there is J4, an RCA phono jack on top of the chassis, which provides a direct injection point to the plate circuit of V4, a 6BA6. It is marked “Q Mult”. If you have a 75S-3 series set, there is no equivalent jack because of the standard included rejection tuning system. You’ll need to inject between chassis ground and pin 5 of V6, a 6BA6, using a series coupling cap as described previously.) Using either CW or SSB mode of operation (either sideband is suitable), you should hear a tone when the sig gen is con-

## *Service Line* (Cont'd)

nected to the IF stage. For an AM-only receiver, the unmodulated IF sig gen signal will produce an S-meter reading, but no tone from the speaker. You should also get an indication on the S-meter; depending upon the set design, S-meters may be driven from the IF amplifiers (as in the 75S- series) or from the AVC/AGC bus.

Bear in mind that failure to hear anything at this point could also indicate detector circuit problems (located right after the last IF stage and before the top end of the volume control pot). Check for bad connections, bad coupling caps, or bad resistors anywhere in the detector circuitry. The detector stages may also be used to generate the AVC voltage (sometimes termed "AGC" for "Automatic Gain Control") that is used to control gain in various stages of the receiver. If AVC is shorted to a bias voltage rail, it is most likely that the receiver itself is fine, but as many as two or even three stages may be fully cut-off due to design limitations.

If you do get a tone and/or S-meter reading at this point, move the sig gen injection point to a location ahead of the IF filters. Note that in many radios, there are multiple filters provided for the various modes of operation: SSB, CW, and AM, to name three. There will be varying amounts of insertion loss and, of course, varying working bandwidth for each of the various filter types. However, any good, working filter should pass the sig gen signal through to the following stages. If this does not happen, look for problems in switch contacts or the filters themselves. S-Line note: with the exception of the AM filter (which is really a pair of IF transformers), the mechanical or crystal IF filters in your set generally have a matched BFO crystal that has to be switched in correctly in order for the product detector to work with the given filter. Don't forget to check for BFO operation if you get a signal through on AM but not on other modes, or if signals that you can hear do not seem centered in the filter's pass-band.

OK, now you are also getting a signal through each of your filters, but the radio still seems dead on all bands. At this point, a decision needs to be made. For receivers such as the Collins 75S- series, working toward the front end of the radio, you have the following stages:

- The rejection tuning system (75S-3 [standard issue] and 75S-1 [if equipped with the Waters version])
- The second mixer
- The second oscillator (the 70K-2 PTO)

Because these receivers have "VFO Output" jacks for use in transceiving with a 32S- series transmitter, it is easy to determine if the PTO is operating. You may connect any of the following to the "VFO Output" jack; an RF voltmeter; an oscilloscope; a frequency counter. A few things to keep in mind:

- a. The PTO operates over the range of 2.5 to 2.7 MHz only - it does not change when bands are switched.
- b. The preferred RF voltmeter would be the HP 410-series, or similar, with a true RF detector probe. General purpose VTVMs, such as the venerable RCA Voltohmismist™ detect an AC signal and convert it to DC within the meter body, not the AC probe. Such meters can give very erroneous readings at frequencies higher than a few hundred kHz.
- c. Because of the relatively low operating frequency of the 70K-2 PTO, its output can be readily viewed on inexpensive oscilloscopes having only 5 MHz or so usable bandwidth. It is better if you have a scope with greater bandwidth, but even a modest scope can be a big help.
- d. Remember that there is a cathode follower stage in the 75S- series receivers that drives the signal to the "VFO Output" jack. If that cathode follower tube is bad, the PTO may be work-



*Service Line* (Cont'd)

ing just fine, but you'll think it is dead. So, if you detect no output at the "VFO Output" jack, do one more thing before launching into an all-out panic regarding the PTO: take your frequency counter input cable or your scope probe and loop it around the 6AU6 tube of the 70K-2 one or two turns. If the PTO is running, you should see an indication on the counter or scope. See e) if you do not have a scope or frequency counter.

- e. An RF "sniffer" can be a handy gadget to have when servicing radios. It is very useful for locating dead oscillators, peaking oscillator output, and tuning up frequency multiplier chains. Although I still like the HP 410 meters best, you can do a very good job using nothing more than a Schottky (or point-contact) diode, a sensitive meter movement, and a pot. Figure 3 shows a small probe (the "sniffer") producing a reading on a 50  $\mu$ A meter that has a 200k ohm pot in series. The probe contains a Schottky diode and by-pass cap that attach to the meter via a length of subminiature coax cable, such as RG-174/U. You can usually confirm oscillator operation by just placing the tip of the non-conducting probe near the tube in question.

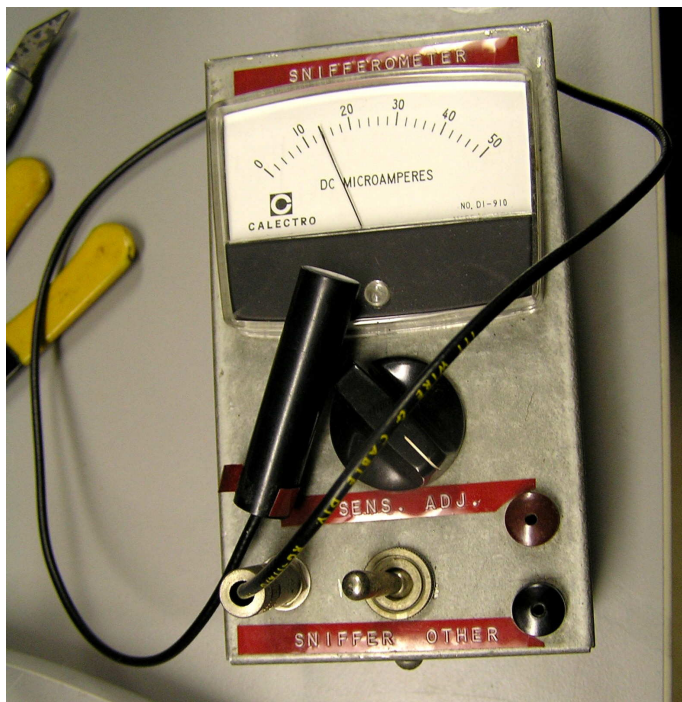

**Figure 3. RF Sniffer that can be constructed with a Schottky diode and a sensitive micro-amp meter**

tube testers: A quality mutual conductance type of tube tester (as exemplified by the well-known TV-7/U family of military testers) will do the following: 1) It will tell you if a tube's filament is working or not; 2) it will usually tell you if a tube is shorted or gassy (detecting a shorted tube is important in preventing damage to the radio set itself); 3) it will demonstrate relative gain (at low frequencies) of one tube of a given type against another of the same type. A tube tester can not be counted upon to give you accurate gain readings when used in RF circuit applications. So, while I do concur with those who say that substitution is the only sure way to know if a tube is "good" in a given application, I also say that I do not generally plug an unknown tube into a working set without first plugging it into my tube tester to check for shorts (I do that even for "NOS" tubes - you never know!).

When working on receivers other than the S-Line or A-Line, bear in mind that the general configuration of sets with dual conversion design was to have the VFO bandswitched and inject into the first mixer, followed by a fixed-frequency (usually crystal controlled) second oscillator to drive the second mixer. Also, there are a number of single conversion sets (usually of the less expensive variety) that convert directly to 455 kHz at the first mixer and that's it. No second mixer or oscillator, and usually more rudimentary means of developing IF selectivity. Such variations in receiver design is just one good reason why it pays to know and understand the circuitry of the set upon which you are working prior to "digging in".

Regardless of the radio, if the second oscillator is running but you still do not hear signals from even the internal crystal calibrator, check the 2<sup>nd</sup> mixer stage for bad connections, bad coupling caps or tuned circuit inductors, resistors with changed values, or a bad tube.

At the risk of igniting a flurry of scorching letters to either the editor or myself, let me state the following about my beliefs on the use of

## *Service Line* (Cont'd)

At this point, you have a receiver that is working from the second mixer on back. The remaining stages are the first mixer, the first local oscillator, the RF pre-amplifier, and the preselector. If the set has a crystal calibrator, it is included with the front end stages. Finding the problem is just a continuation of what you have been doing so far: inject signal, check for broken connections, bad components, and misadjusted trimmers or slugs in the preselector and input pre-amp stages. Since the front end is almost always band switched, check for problems with the band switch itself. If a set works on some bands but not others, the cause of the problem is very often right in the band switch itself or components attached to it.

In multi-band radios, there is always a lot of switching in the front end so as to properly select components for each frequency range. That switching affects both the antenna input signal path (which includes the RF pre-amplifier and pre-selector) and the first oscillator signal path (which includes the frequency determining elements for that circuit). For S-Line and similar sets, the first oscillator is controlled by any one of many crystals that are in a bank and are switch selected by band. A poor contact within a switch section means that the oscillator will not function on at least one band.

There have been many postings on the CCA Reflector about the S-Line/KWM-2 bandswitch, both about problems that can occur with it and proper techniques for removing the switch shaft and shield cans, then cleaning the switch wafers. Keep in mind the fact that the various shield partitions that are part of the bandswitch assembly are very important with respect to stable performance of the radio. The shields must have low impedance paths to chassis ground or you will be treated to a chorus of squeaks, squawks, and other strange noises. The hardware that secures the shields must be clean and tight to the chassis.

Finally, consider the old line about “rounding up the usual suspects” when trying to analyze problems in the front end, or elsewhere. To sum up the comments in previous paragraphs – look for:

- Poor switching contacts (oxidized, poor contact pressure, etc.)
- Open coupling caps
- Shorted by-pass caps
- Carbon comp resistors that have changed value (especially true for values of 100k ohm or more)
- Bad tubes (low emission, gassy, internal shorts)
- Open or shorted solid state devices when present (diodes, transistors)
- Bad or broken solder connections

With regard to bad tubes, note that Collins did make extensive use of the 6U8A tube in the S-Line equipment. Much has been written about that tube on the CCA Reflector over the past several years. I can personally attest to the fact that 6EA8 tubes are an excellent replacement for the 6U8A, and I recommend you consider getting some 6EA8s to have on hand. In fairness, I must also note that people have been cautioned to NOT replace the 6U8A that serves as the tone oscillator in the KWM-2/2A sets with the 6EA8. Otherwise, I am not aware of any other “unwise” substitutions for the 6U8A.

This concludes receiver troubleshooting. The next article in this series will be the compliment to this one – transmitters that partially work. In the meantime, have fun and enjoy one of those fine, old Collins sets that continue to populate our lives.

de Dale Svetanoff, WA9ENA

## *Service Line* (Cont'd from last issue)

### Reducing Product Detector and BFO Noise in 75S-3 Receivers – Part 2

by Dick Weber, K5IU

In part 1. I discussed how I reduced the noise in the product detector and BFO in the 75S-3/3A by making two, simple modifications to the circuitry of V8. The first change was to remove L16 and C34 and replace them with a 1.6 k Ohm resistor – pin 8 to ground. The second step was to replace L12 with a shielded 1000 uH choke.

Now on to the 75S-3B/C: I have a 75S-3C built in 1966 that I also used to look at the problem of noise produced in the product detector and BFO. This receiver came from the factory with L16 and L12 as unshielded, ferrite chokes with L16 in parallel with C34 – just like in the 75S-3 – including component values. In its standard configuration, the hum and hash levels were lower than those of my 75S-3As before they were modified. I believe there's a valid reason for this. In the 75S-3, L16 and L12 and some related components are piled-up over V8 and are in very close proximity to each other. Not so in the 75S-3B where the physical layout of the V8 circuitry is substantially different – using a turret (TB1) to support some components hooked to V8. By using a turret, components are not piled-up over V8 and some parts, such as L12, but are stretched out away from V8 minimizing coupling between parts. It seems that the factory may have known about the hum/noise problem in the 75S-3 because they used a different circuit lay out in the 75S-3B.

My curiosity got the better of me, which resulted in replacing the factory L16-C34 combination and L12 in my 75S-3C with shielded 1000 uH chokes as with my 75S-3As. The hum/hash levels were noticeably better. After a bit of investigation, I found that in late model 75S-3Bs Collins switched to shielded versions of L16 and L12. My 7<sup>th</sup> edition owner's manual (1975) is the first one I have that shows this change while my 5<sup>th</sup> edition (1968) shows unshielded chokes being used. I don't have the 6<sup>th</sup> edition, so I'm not sure what it shows. Regardless, late in the production of the 75S-3Bs, Collins must have realized that using shielded chokes would further reduce these noises, but no service bulletin was issued.

Again I tried using a 1.6k Ohm resistor in place of the 1000 uH shielded choke I just installed as replacement for the old L16-C34 pair. Here too the resistor resulted in lower noise as compared to the shielded L16 of 1000 uH. When the BFO was off, noise was reduced by about 9.0 dB using the resistor as compared to the shielded L16. When the BFO was on, using the resistor dropped the noise by about 9.2 dB. I need to point out that, to begin with, the noise in the 75S-3C with shielded L16 and L12 chokes was about 10 dB lower than the 75S-3As with the same shielded chokes. As dis-

cussed above, this is probably due to the improved layout of components around V8. Regardless, using the resistor in place of a shielded L16 in my 75S-3C showed additional improvement.

If you have a late model 73S-3B/C where L16 and L12 are shielded chokes, it may not be worth the trouble to remove L16 and C34 and replace them with a 1.6 k Ohm resistor. On the other hand, if your 75S-3B/C has L16 and L12 chokes that are not shielded, consider making the same changes I made. For both my 75S-3As & 75S-3C, the hum and hash have been reduced significantly by replacing L12 with a 1000 uH shielded choke and replacing L16 and C34 with a 1.6k Ohm resistor. The shielded 1000 uH chokes I used are API Delevan pn 1641R-105K. I bought these from Mouser – their pn 807-1641R-105K. I would like to hear from anyone who makes these changes or has thoughts about them.

As stated earlier, I found that the 75S-1 and early 75S-3 receivers used resistor R26 from pin 8 of the product detector tube to ground. After production of the 75S-3 began, Collins replaced R26 with L16 and C34. Then in late model 75S-3Bs, L16 (and L12) was changed to a shielded version. So here I am having gone back to using a resistor in place of L16 and C34. I never would have guessed that part of my solution was to take a step backwards. Or was it two?

-----CCA-----

## 20V Conversion (Cont'd)

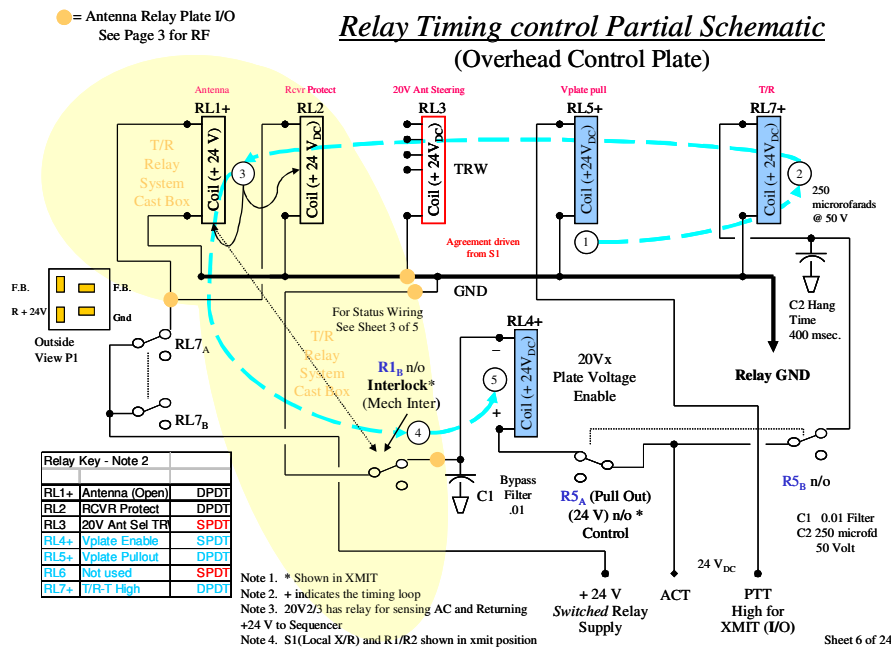

Figure 3. Sequencer and Antenna Control Partial Schematic for Timing Relays

bottom compartment make up with wiring that is in the factory position as a guide for assembly.



Figure 4. High voltage bottom compartment of the 20V-3 showing placement of the harness and component wiring

A very nice way of adding the required internal control relays, or the 50 V-A transformer used for adding lighting to the meter panel, is to install a sub-panel above the existing barrier strip area. On the 20V-3, this can be done with existing holes as shown in the photos.



Figure 5. Control panel added in the 20V-3 interface area

A mechanically stable and nice crystal/VFO interface can be built in a small project box. The design I used has two male chassis octal plugs on the under side of the box carefully placed so that the box clears the oscillator tube and mechanically plugs into both crystal sockets. Mount the plugs carefully on the back of the box with a little clearance in the



Figure 6. Crystal and VFO interface box to be plugged into existing crystal sockets

## 20V Conversion (Cont'd)

mounting holes, or you will not be able to get them aligned to both sockets at one time. The crystal selected is routed to the top crystal socket and the VFO is routed to the bottom, allowing you to select crystal or VFO control from the front panel of the 20V with the existing 20V crystal switch.

If you decide to use this interface method, do not do what I did. It all worked very well, except I could not find the rotary switch I was looking for, so I used toggle switches. Works great, looks great, but there is just a little too much stray capacitance. As a result, I can not get my frequency to adjust up to better than 50 cps low due to capacitance in the switches. Use a low capacitance rotary switch.

In my case, I decided to bring all control lines and the VFO and monitor lines in through a single interface box which also has a manual PTT switch which I can toggle from the back during maintenance. I used bypassing on all lines with a single-point grounding concept to try and keep as much RF off the control lines as possible. This seems to have worked well. The balanced pair audio does not come through this box. You do not want to break your audio ground, nor do you want this ground that close to the RF grounds.

### In Conclusion

I wish you well with your project. Hopefully, as they say in the manuals, you have read all the instructions before you started. When you are done, with proper cleaning, stock circuitry (and some slight modifications as noted) and a straight-forward conversion, you will be rewarded with a very reliable and physically and emotionally satisfying transmitter that will take you back to the good old days of AM radio.

Again, my sincere thanks to Stu Bonney, K5PB, who helped me with the RF simulations that led to a very successful conversion. His thoughts and ideas were of great help.

K0CXX is owned and operated by the Mogollon Rim Collins Collectors Club, Bill Carns (N7OTQ) trustee. The station is operated in honor of Art Collins (W0CXX, 9CXX). The transmitter and studios are located in the Hill Country of Central Texas. K0CXX operates on a frequency of 3855 kc with a carrier power of 375 watts.

Please do not hesitate to call or contact me if you would like to talk.

73s Bill

**300G-1 Coming  
soon to the  
K0CXX studio**



### *Did You Know?*

Collins Radio - now Rockwell Collins by name - is again a stand alone publicly traded company with the stock exchange call of COL. It was divested by Rockwell International, along with a number of other divisions, in 2001. They are again headquartered in Cedar Rapids, Iowa.

When purchased by Rockwell in 1971 - 72, Collins Radio had an annual revenue of \$287 M (1971). Today, after continuing success and many acquisitions (some 11 by report), their 2008 annual revenue was in excess of \$4.7 Billion with earnings per share of \$4.17 and a healthy return on invested capital of 33%. Their stock is currently trading above \$40 per share.

They remain leaders in the fields of Avionics - serving mainly the airline industry, business and military sectors - and Government Systems - both domestic and foreign.

Sometimes we lose sight of the "now" perspective as we concentrate on the collectable past.

With over 20,000 employees, Collins is now stronger than ever. They have changed their business model with the times - as is wise in these days of dying US corporations.

They continue their history of innovation and leadership.

July, 2009

-----CCA-----

## CCA Has Great Dayton Hamvention

By Tony Sokol, W9JXN

Another Dayton has come and gone in a heart beat and this year's event turned out to be another hit. Despite gloomy predictions stemming from our dyer economic situation, Dayton 2009 came off much better than expected on all fronts. In a conversation with one of DARA's directors, I learned that, during the last week or so before the event, sales of spaces both inside and outside jumped up over last year's total - a pleasant surprise. Although there were a lot of open spaces outside, the crowds were good.



Jim Stitzinger's Collins demo van was back again this year compliments of the ARRL. The CCA booth looked great once again thanks to Floyd W8RO and his crew (Rich and Bob) who handled its transportation, set up, and tear down. We had a constant flow of visitors and signed up many new members on the spot. Actually, more so that I can remember in previous years.

All I can say about the banquet is WOW! Two years ago we were pushing to get 50 attendees. Last year we jumped up to 80. This year, we topped over 100 attendees and received many great com-



Bill Wheeler at the mic

ments. Bill Wheeler K0DEW, one of the founders of the CCA, kicked off the banquet with a warm and informative welcome. Bill has since been elected to the CCA Board of Directors. Rod Blocksom, K0DAS, gave us a great presentation on how world events have moved Collins to explore, develop, and produce new products and technology to meet communication needs ranging from Admiral Byrd's expedition to the Apollo moon mission and beyond.

The Thank You this year is large. Our Dayton co-chairman and President Paul Kluwe, W8ZO, did a great job of rounding up prizes, generating name tags, and procuring the awards to be

handed out during the banquet. Mike, K4QU did a great job of manufacturing the very classy laser etched plaques. Also a big thanks to the many others that helped bring it off like Jim Green and his wife Millie who checked everyone in and made sure they received the meals they ordered. Then there were our runners Brian, W9SRK, Jim, W2IMK, and Paul, W8ZO who helped distribute the door prize cache. (There may have been more but I lost track in the heat of the battle.) Of course, there was my ever present helper Barb, KB3MPF, who helps with

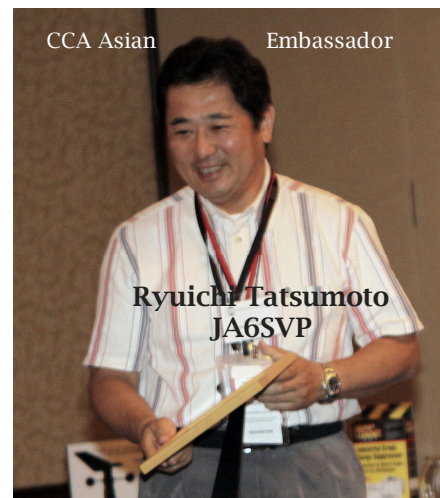

CCA Asian Ambassador

Ryuichi Tatsumoto  
JA6SVP

the door prize name drawing. Also a tip of the hat to Rich, WB3JLK, who took care of the Dance Cards. I hope I haven't missed anyone but as you can see it takes a lot of individuals to pull off a successful event like this and, thanks to these and several others, we had another great Dayton experience. And...yes, we are already planning for next year. We have a good lead on a very interesting presentation for next year and I have



## In the Shack of Ted Hartson, WA8ULG

This quarter's Signal features the shack of Ted Hartson, WA8ULG. Ted is a relative newcomer to the CCA but very welcome. He is certainly not a newcomer to Collins, although one would hesitate to call him a collector. Being in the "business", Ted has a strong philosophy that every radio earns its place in his shack. He might better be described as a user, rather than a collector.

Ted is a rather self educated broadcast engineer and entrepreneur having, at one time, been involved with two TV broadcast related companies, the last of which developed embedded data in NTSC streams. He had obtained his First Class Commercial by the age of 17.



He is now retired with his lovely wife and they are at home in both the Scottsdale, AZ area and in Parks, AZ near Flagstaff where he claims to be an Irish Setter herder.

As you can readily tell from the pictures, functionality is what is important at Ted's place. He has been a ham since 1967 (WN8ULG) some 42 years and obviously he is not into vanity calls or pretenses. He claims to have some other (unnamed) hobbies, but he would not reveal them since he says this would only cause a disagreement with his wife who claims he is "Just a Ham."

His first piece of Collins, and still his favorite, was a 51J-3. Along the way he has occasionally strayed away from strictly Collins, but his shack now features many Collins rigs with one of the stars being his beloved 820D-2. Affectionately known as "The Rock", this 1 Kw broadcast beast is rock solid but fraught with frustrations when converting it to the ham bands since the oscillator up to the driver are digital. Ted has home brewed a conversion that now covers 160, 75 and 40 meters.

By the way, when asked about the dog and the fire bottle, he explained that the dog is trained to grab the fire bottle and put out any flames that resulted from up-mod in excess of 140%.

There Ted, now you are officially a "Rock" star. Hi!

**Ted's Favorite Fire Dog**



**Favorite 51J-3**



**820D RF Chain ala Ted**

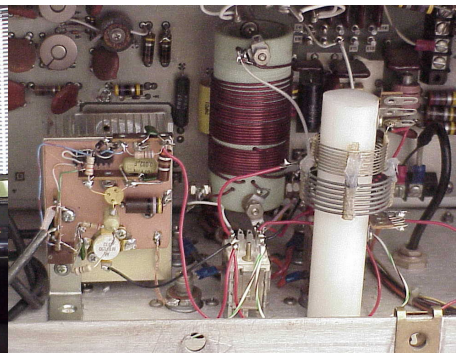

### From the President



With Paul's permission, we are taking a bye on this quarter's President's column.

Paul is in the midst of a major move and career change. As most of you probably know, Paul has been semiretired of late and acting also as the City Manager of a small town in Michigan.

Things have changed—Paul has accepted a challenging position as the CEO of a GM spin-off and his wife, a Doctor, has accepted a new position as well.

They are in the process of moving (my sympathies Paul) to Tennessee where Paul will be setting up his new company's headquarters and where his wife has joined a new practice.

We wish them both well.

I do know that Paul has commented strongly about how glad he is to see Bill Wheeler back on the Board and I am sure that he would share these sentiments if he were not in a box somewhere en route.

-----CCA-----

### From the Editors' Desk

(Cont'd)

Send Membership Dues to:

**Collins Collectors Association**  
Box 316, 9121 Atlanta Ave  
Huntington Beach, CA 92646

See [collinsradio.org](http://collinsradio.org) site for more info.

Stay tuned also for some new exciting membership benefits that are in the planning phase.

Personally, this has been a very satisfying quarter for me, albeit a busy one, as I have finally (for the most part) completed my shop/shack building and almost all of the equipment has been moved into place in the shack. I am starting to do some serious hook up of antenna and control

### Dayton 2009 (Cont'd)



signed and returned the 2010 contract with the Holiday Inn.

If you missed this year,

don't procrastinate! Put Dayton on your calendar for 2010 and join your Collins family for another great weekend of camaraderie in Dayton. Oh, and if you can not wait, don't forget the Collins cruise that Butch KOBS and the gang are planning later this year.

73s de Tony Sokol - W9JXN  
2009 Dayton Co Chairman

-----CCA-----

wiring. By the time you all get the Q3 issue, N7OTQ & K0CXX will be on the air from Wimberley, Texas.

The Q3 *Signal* Shack of the Quarter will be featuring some pictures and you are all - seriously - invited to come by, have an 807 or two, and spend some time operating or just visiting in the shack. That is what it was all for.

Band conditions seem to be picking up a bit. There have been some real active nets, both on the low bands and even on Sunday afternoon 20 meter net and some DX (what is that anyway?) has even been heard on 20 meters.

de Bill Carns, N7OTQ  
[wcarns@austin.rr.com](mailto:wcarns@austin.rr.com)

-----CCA-----

The **Signal Magazine** is published quarterly by The Collins Collectors Association Copyright© 2009, all rights reserved.

**Editor** Bill Carns, N7OTQ  
**Co-Editor,** Joe Nyberg, W1LJN

#### Board of Directors

Paul Kluwe, W8ZO, President  
Bill Carns, N7OTQ, Vice Pres.  
Jim Stitzinger, WA3CEX, Secretary  
James Green, WB3DJU, Treasurer  
Bill Wheeler, KODEW, PR  
Butch Schartau, KOBS, Events

*The CCA is licensed by Rockwell Collins to reproduce and disseminate Collins copyrighted documents related to Collins amateur radio products.*

The Collins Collectors Association  
P.O. Box 354

#### Technical Disclaimer

The information contained in this publication is believed to be reliable. However, no responsibility is assumed for inaccuracies or omissions. The CCA, anyone who is a member, and the authors of said material shall not be liable to anyone with respect to liability, loss, or damage caused, or alleged to have been caused, directly or indirectly by this publication or the contents herein.